

6

5

4

3

2

1

Item	Part number	Description	Qty
1	FL-210	Folding Ladder Main Frame Assembly - Two Rung	1
2	FL-220	Two Rung Ladder Assembly	1
3	M1225ALF	M12x25 Anti-Luce Fastener	1
4	BHGY1185	Tailgate washer UV stable 28mm	1

D

D

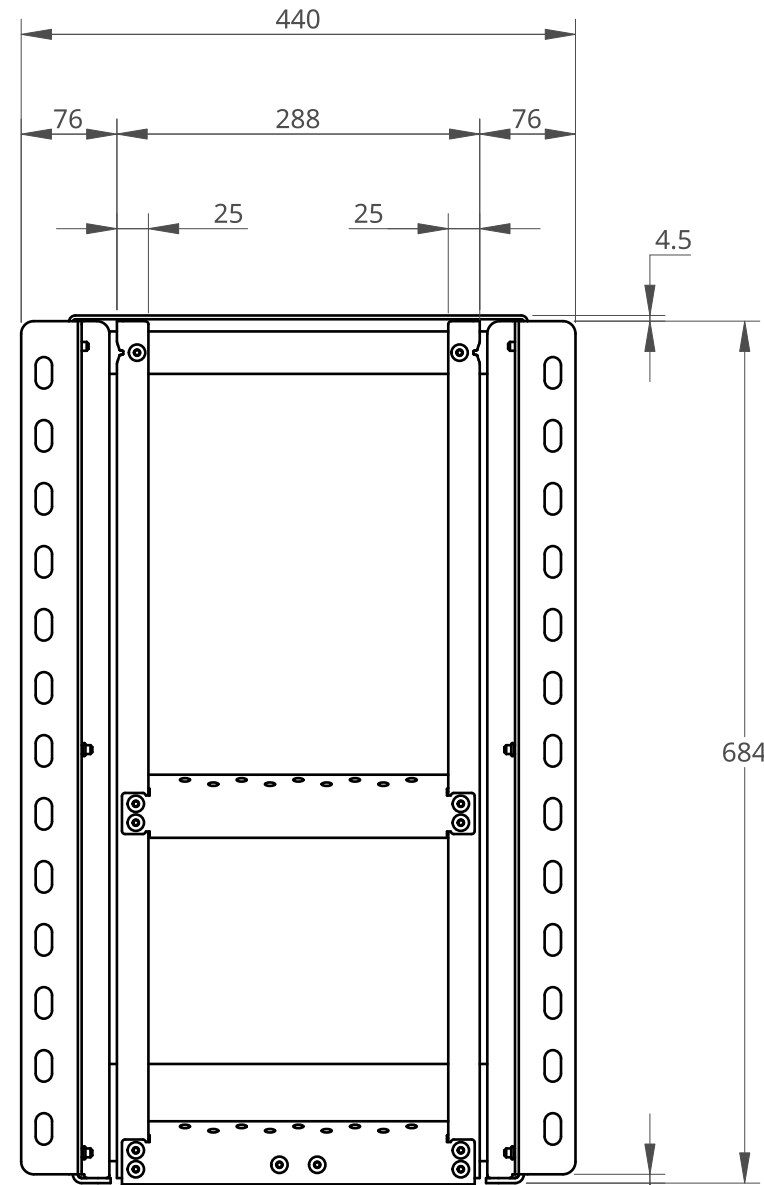
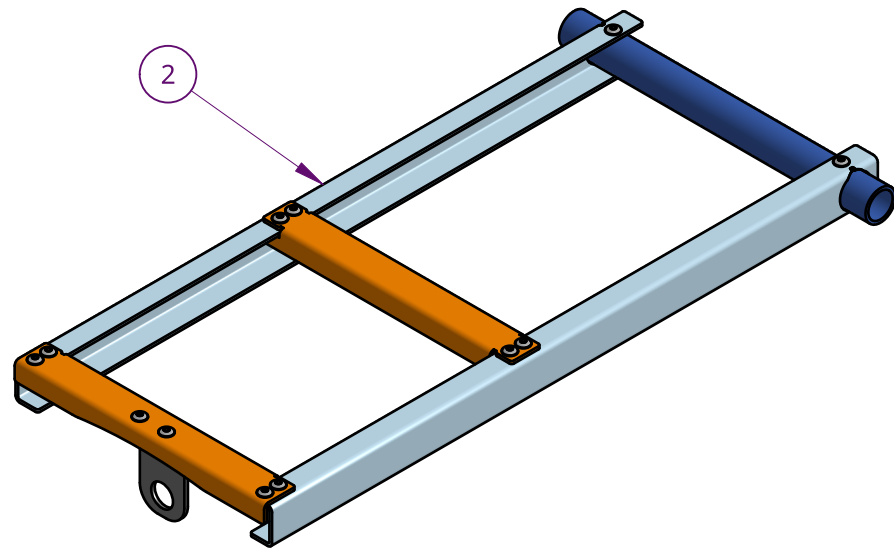

TOP VIEW

FRONT VIEW

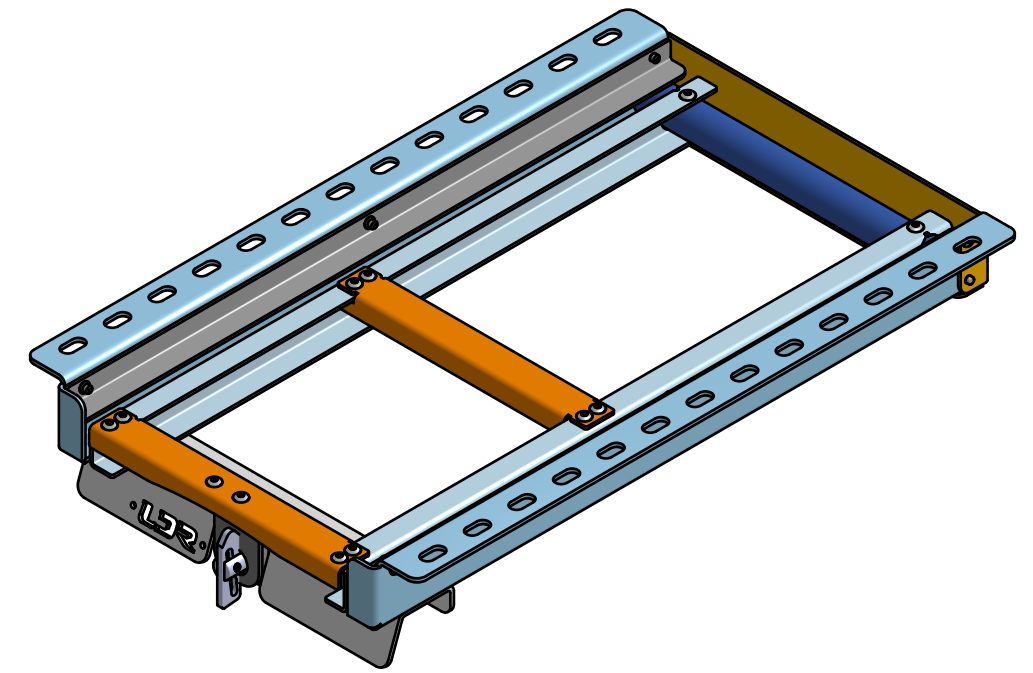

PICTORIAL VIEW

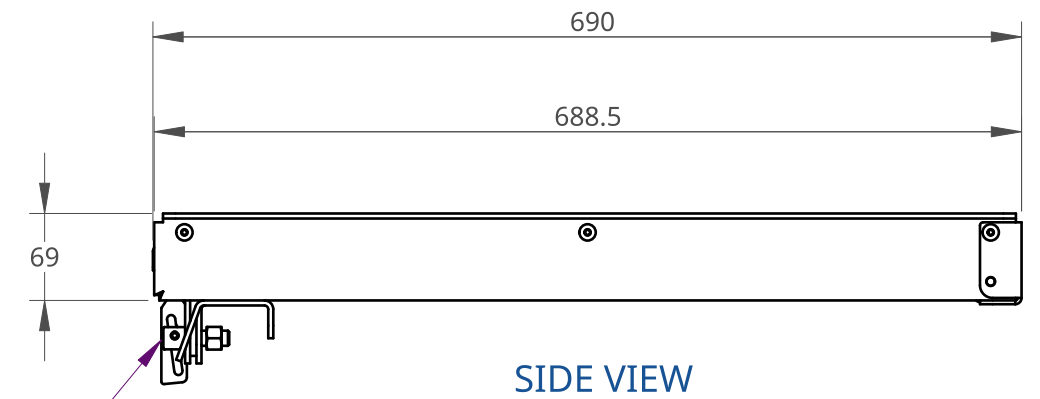

SIDE VIEW

C

C

B

B

A

A

HEX NUT OF ITEM 3
INSTALL FROM THIS SIDE

ANTI-LUCE FASTENER BOLT OF ITEM 3
INSTALL FROM THIS SIDE

EXPLODED VIEW



INDUSTRIES
 38 Activity St, Warwick Qld 4370 Ph: 07 4661 2730
 Email: sales@ldrindustries.com.au
 Website: ldrindustries.com.au

Rev.	Description	Date	Issued by
1	ISSUED FOR MANUFACTURE	29/09/22	LPV

REVISIONS

GENERAL NOTES				JOB NAME		QUANTITY		TITLE	
FINISH UNLESS OTHERWISE SPECIFIED, DIMENSIONS ARE IN MILLIMETRES BREAK ALL SHARP EDGES AND REMOVE BURRS TOLERANCES: LINEAR: 1-1000 ± 0.5 >1000 ± 1.0 ANGULAR ± 0.5° UNLESS NOTED OTHERWISE						1		FOLDING LADDER ASSEMBLY - TWO RUNG FL-200	
						WEIGHT			
				JOB NO.		THICKNESS		DWG NO.	
DRAWN		NAME		DATE		MATERIAL		REV.	
APPV'D		LIEZEL VISTAN		28/09/22				1	
						SCALE 1:6		SHEET 1 of 1	
						DO NOT SCALE DRAWING			

6

5

4

3

2

1